

# L293D QUADRUPLE HALF-H DRIVER

SLRS008A – SEPTEMBER 1986 – REVISED MAY 1990

- 600-mA Output Current Capability Per Driver
- Pulsed Current 1.2-A Per Driver
- Output Clamp Diodes for Inductive Transient Suppression
- Wide Supply Voltage Range 4.5 V to 36 V
- Separate Input-Logic Supply
- Thermal Shutdown
- Internal ESD Protection
- High-Noise-Immunity Inputs
- Functional Replacement for SGS L293D

## description

The L293D is a quadruple high-current half-H driver designed to provide bidirectional drive currents of up to 600-mA at voltages from 4.5 V to 36 V. It is designed to drive inductive loads such as relays, solenoids, dc and bipolar stepping motors, as well as other high-current/high-voltage loads in positive-supply applications.

All inputs are TTL-compatible. Each output is a complete totem-pole drive circuit with a Darlington transistor sink and a pseudo-Darlington source. Drivers are enabled in pairs with drivers 1 and 2 enabled by 1,2EN and drivers 3 and 4 enabled by 3,4EN. When an enable input is high, the associated drivers are enabled, and their outputs are active and in phase with their inputs. External high-speed output clamp diodes should be used for inductive transient suppression. When the enable input is low, those drivers are disabled, and their outputs are off and in a high-impedance state. With the proper data inputs, each pair of drivers form a full-H (or bridge) reversible drive suitable for solenoid or motor applications.

A  $V_{CC1}$  terminal, separate from  $V_{CC2}$ , is provided for the logic inputs to minimize device power dissipation.

The L293D is designed for operation from 0°C to 70°C.

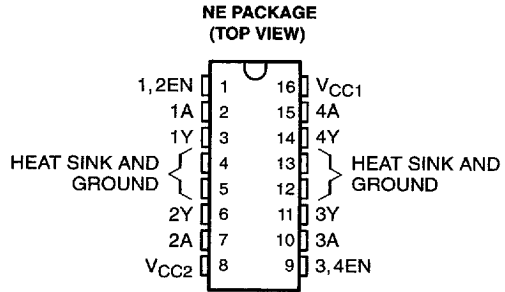

## logic symbol†

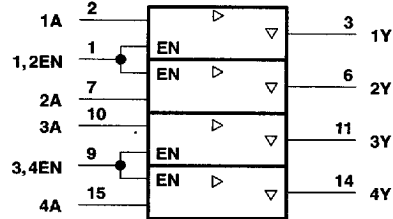

† This symbol is in accordance with ANSI/IEEE Std 91-1984 and IEC Publication 617-12.

## logic diagram

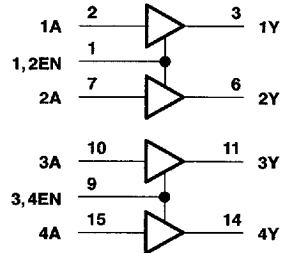

**FUNCTION TABLE  
(each driver)**

INPUTS‡		OUTPUT
A	EN	Y
H	H	H
L	H	L
X	L	Z

H = high-level, L = low level,  
X = irrelevant, Z = high-impedance (off)  
‡ In the thermal shutdown mode, the output is in the high-impedance state regardless of the input levels.

PRODUCTION DATA information is current as of publication date. Products conform to specifications per the terms of Texas Instruments standard warranty. Production processing does not necessarily include testing of all parameters.

**TEXAS  
INSTRUMENTS**

POST OFFICE BOX 655303 • DALLAS, TEXAS 75265

Copyright © 1990, Texas Instruments Incorporated

8961724 0100997 30T

3-11

# L293D QUADRUPLE HALF-H DRIVER

SLRS008A – SEPTEMBER 1986 – REVISED MAY 1990

## schematics of inputs and outputs

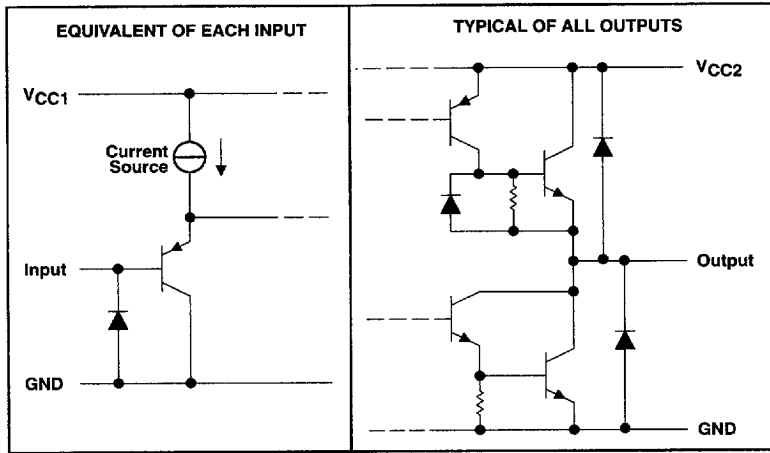

## absolute maximum ratings over operating free-air temperature range (unless otherwise noted)

Logic supply voltage range, $V_{CC1}$ (see Note 1)	36 V
Output supply voltage range, $V_{CC2}$	36 V
Input voltage range, $V_I$	7 V
Output voltage range, $V_O$	-3 V to $V_{CC2} + 3$ V
Peak output current (nonrepetitive, $t \leq 100 \mu s$ )	$\pm 1.2$ A
Continuous output current, $I_O$	$\pm 600$ mA
Continuous total dissipation at (or below) 25°C free-air temperature (see Notes 2 and 3)	2075 mW
Continuous total dissipation at 80°C case temperature (see Note 3)	5000 mW
Operating case or virtual junction temperature range, $T_J$	-40°C to 150°C
Storage temperature range, $T_{stg}$	-65°C to 150°C
Lead temperature 1,6 mm (1/16 inch) from case for 10 seconds	260°C

- NOTES: 1. All voltage values are with respect to the network ground terminal.  
 2. For operation above 25°C free-air temperature, derate linearly at the rate of 16.6 mW/°C.  
 3. For operation above 25°C case temperature, derate linearly at the rate of 71.4 mW/°C. Due to variations in individual device electrical characteristics and thermal resistance, the built-in thermal overload protection may be activated at power levels slightly above or below the rated dissipation.

## recommended operating conditions

		MIN	MAX	UNIT
Logic supply voltage, $V_{CC1}$		4.5	7	V
Output supply voltage, $V_{CC2}$		$V_{CC1}$	36	V
High-level input voltage, $V_{IH}$	$V_{CC1} \leq 7$ V	2.3	$V_{CC1}$	V
	$V_{CC1} \geq 7$ V	2.3	7	
Low-level input voltage, $V_{IL}$		-0.3†	1.5	V
Operating free-air temperature, $T_A$		0	70	°C

† The algebraic convention, in which the least positive (most negative) value is designated minimum, is used in this data sheet for logic voltage levels.

8961724 0100998 246



POST OFFICE BOX 655303 • DALLAS, TEXAS 75285

# L293D QUADRUPLE HALF-H DRIVER

SLRS008A – SEPTEMBER 1986 – REVISED MAY 1990

## electrical characteristics, $V_{CC1} = 5\text{ V}$ , $V_{CC2} = 24\text{ V}$ , $T_A = 25^\circ\text{C}$

PARAMETER		TEST CONDITIONS		MIN	TYP	MAX	UNIT
$V_{OH}$	High-level output voltage	$I_{OH} = -0.6\text{ A}$		$V_{CC2} - 1.8$	$V_{CC2} - 1.4$		V
$V_{OL}$	Low-level output voltage	$I_{OL} = 0.6\text{ A}$			1.2	1.8	V
$V_{OKH}$	High-level output clamp voltage	$I_{OK} = -0.6\text{ A}$			$V_{CC2} + 1.3$		V
$V_{OKL}$	Low-level output clamp voltage	$I_{OK} = -0.6\text{ A}$			1.3		V
$I_{IH}$	High-level input current	A	$V_I = 7\text{ V}$		0.2	100	$\mu\text{A}$
		EN			0.2	$\pm 10$	
$I_{IL}$	Low-level input current	A	$V_I = 0$		-3	-10	$\mu\text{A}$
		EN			-2	-100	
$I_{CC1}$	Logic supply current	$I_O = 0$	All outputs at high level		13	22	mA
			All outputs at low level		35	60	
			All outputs at high impedance		8	24	
$I_{CC2}$	Output supply current	$I_O = 0$	All outputs at high level		14	24	mA
			All outputs at low level		2	6	
			All outputs at high impedance		2	4	

## switching characteristics, $V_{CC1} = 5\text{ V}$ , $V_{CC2} = 24\text{ V}$ , $T_A = 25^\circ\text{C}$

PARAMETER		TEST CONDITIONS	MIN	TYP	MAX	UNIT
$t_{PLH}$	Propagation delay time, low-to-high-level output from A input	$C_L = 30\text{ pF}$ , See Figure 1		800		ns
$t_{PHL}$	Propagation delay time, high-to-low-level output from A input			400		ns
$t_{TLH}$	Transition time, low-to-high-level output			300		ns
$t_{THL}$	Transition time, high-to-low-level output			300		ns

### PARAMETER MEASUREMENT INFORMATION

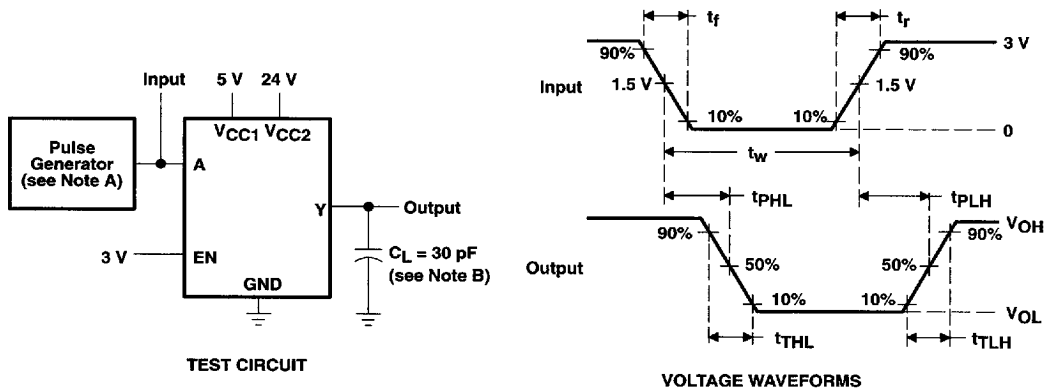

NOTES: A. The pulse generator has the following characteristics:  $t_r \leq 10\text{ ns}$ ,  $t_f \leq 10\text{ ns}$ ,  $t_w = 10\text{ }\mu\text{s}$ ,  $\text{PRR} = 5\text{ kHz}$ ,  $Z_O = 50\text{ }\Omega$ .  
 B.  $C_L$  includes probe and jig capacitance.

Figure 1. Test Circuit and Voltage Waveforms

8961724 0100999 182

**TEXAS  
INSTRUMENTS**

POST OFFICE BOX 655303 • DALLAS, TEXAS 75265

3-13

**L293D  
QUADRUPLE HALF-H DRIVER**

SLRS008A – SEPTEMBER 1986 – REVISED MAY 1990

**APPLICATION INFORMATION**

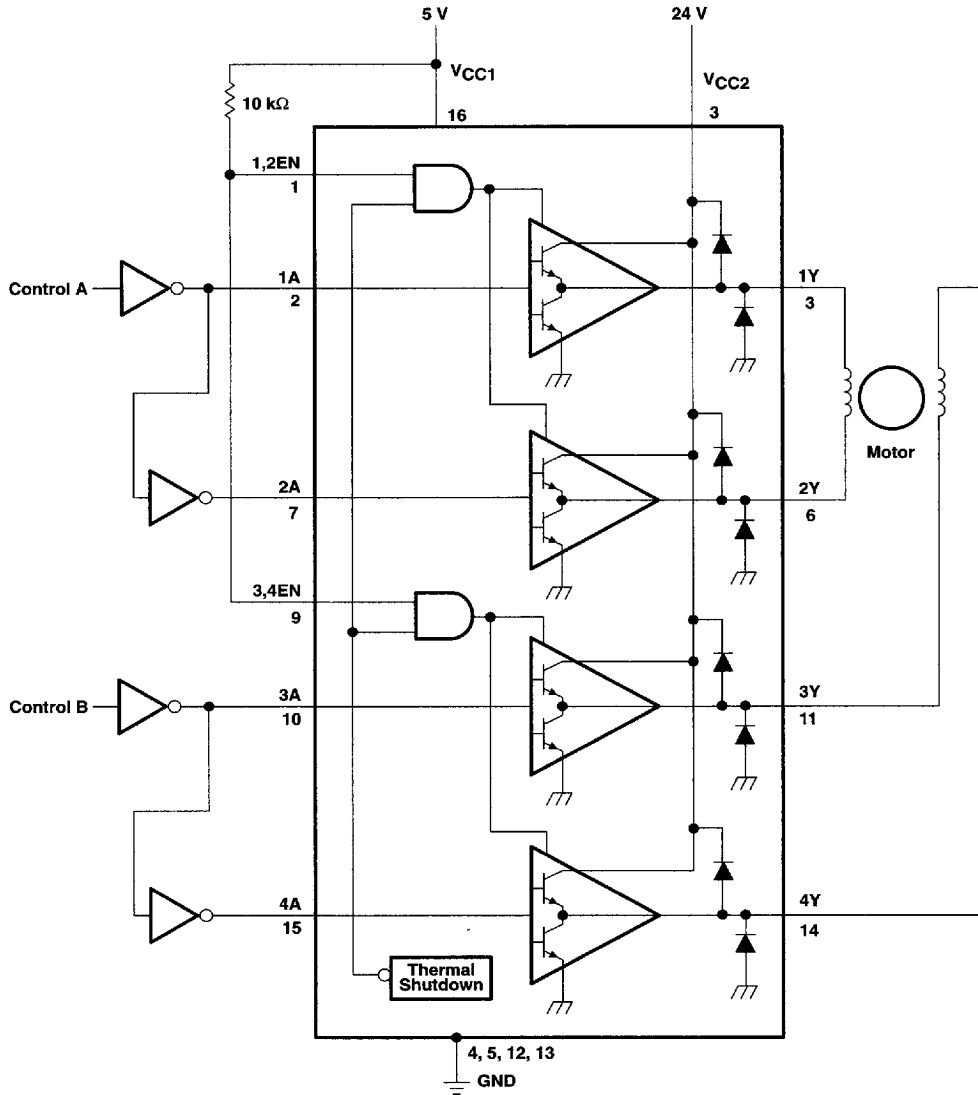

**Figure 2. Two-Phase Motor Driver**

■ 8961724 0101000 5T2 ■

